

Col.-Ftg. Connection
N.T.S.

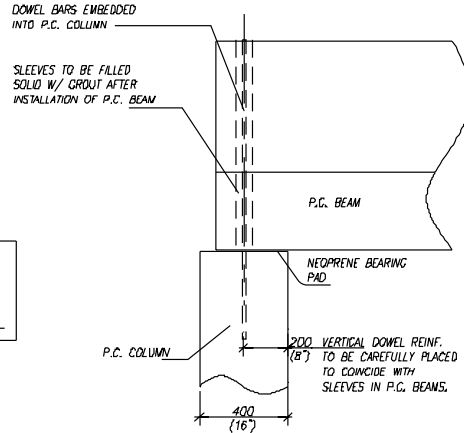

Beam - Column Connection
N.T.S.

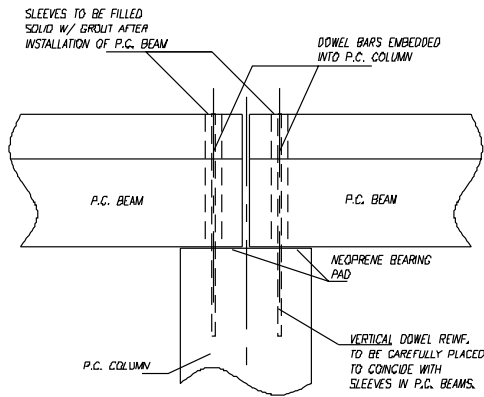

Multiple Beam - Column Connection
N.T.S.

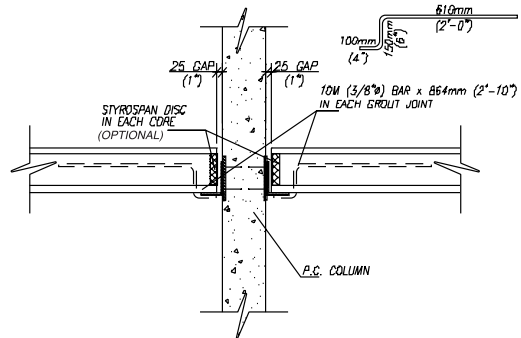

Precast Slab Connection to Column
N.T.S.

All connections shown are to be used for concept design only.

Framing