

Connections to Structural Wood & Balcony Details

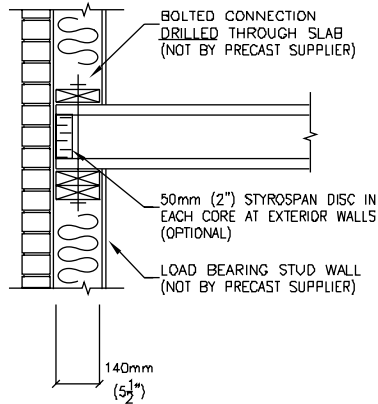

End Bearing On Wood Studs - Bolted Connection
N.T.S.

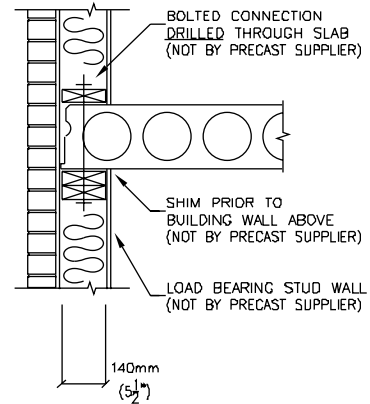

Side Bearing - Bolted Connection
N.T.S.

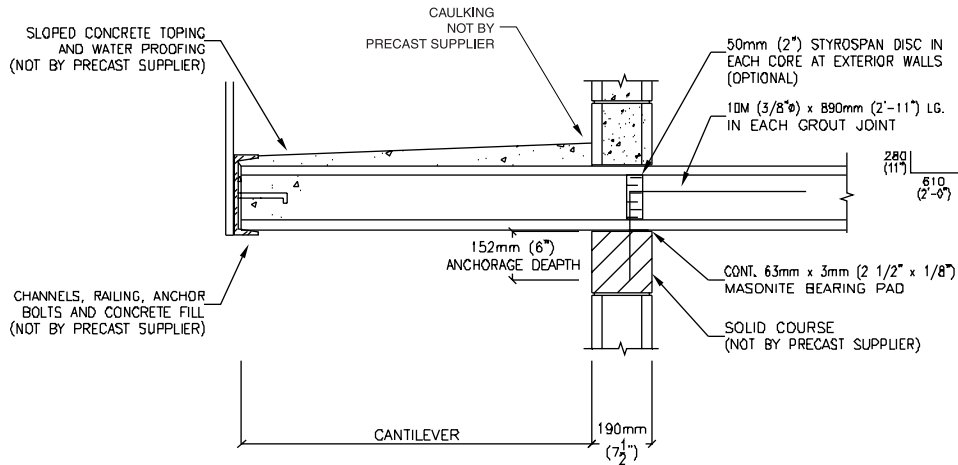

Cantilevered Balcony - Tie Down
N.T.S.

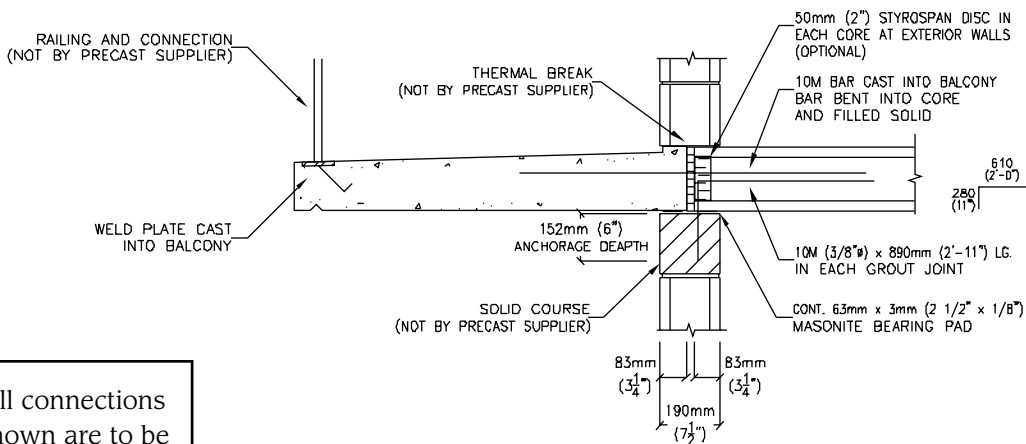

Solid Precast Balcony (Supported On Wing Walls) - Tie Across & Down
N.T.S.

All connections shown are to be used for concept design only.

Flooring/Roofing