

Connections to Masonry/Steel/Precast

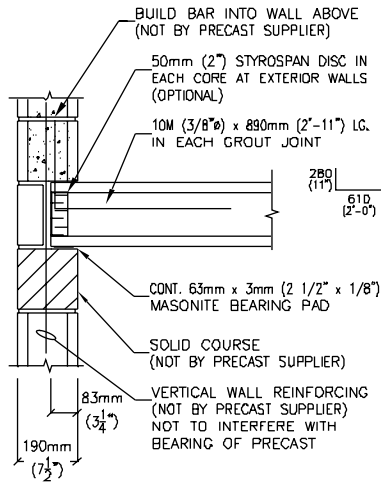

End Bearing On Block - Half Bearing - Tie Up
N.T.S.

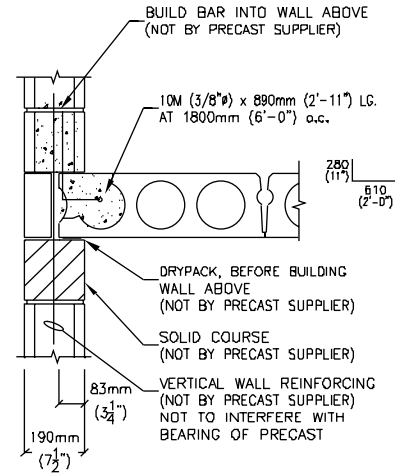

Side Bearing On Block - Half Bearing - Tie Up
N.T.S.

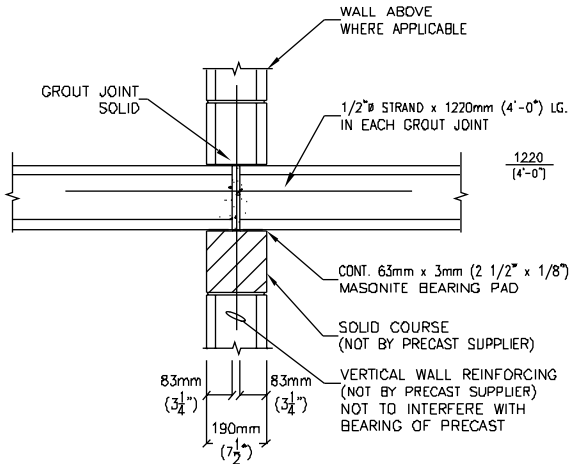

End Bearing On Block - Abutting - Tie Across
N.T.S.

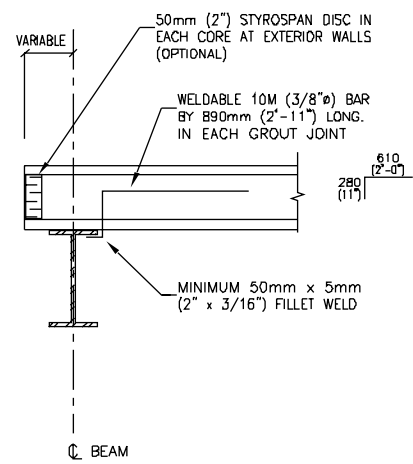

End Bearing On Steel - (63mm or 2fi" min) - Tie Down
N.T.S.

All connections shown are to be used for concept design only.

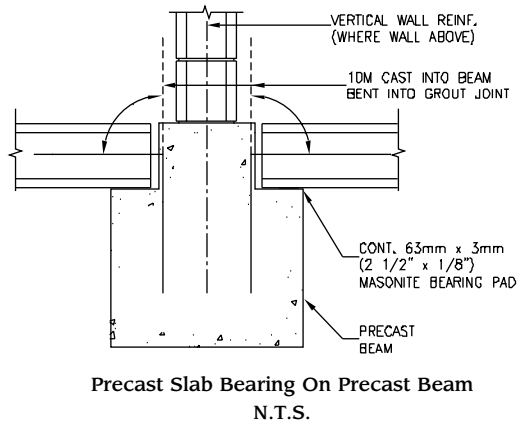

Precast Slab Bearing On Precast Beam
N.T.S.

Flooring/Roofing